

VIII. USE OF CHART RECORDS IN DATA ANALYSIS

Chart records were used to record data for many decades. With the advances of reliable, accurate, and easy to use data loggers, there has been a significant trend away from gathering data on charts. This trend has been facilitated by the development of the microcomputer and has greatly increased the amount of data that can be stored and analyzed. It should be noted, however, that while numerical data are necessary for calculations, a visual representation of the data such as chart records gives a different perspective and in certain instances allows for a better interpretation of the data.

At the University of Oregon Solar Monitoring Laboratory, we use chart records at our first class stations to back up our microprocessor based data logger. At first, the charts were used to provide data when digitized data were not available. It soon became apparent that these chart records provided us with specific information that could not be gleaned easily from the digitized data. The chart records have now become an integral part of the data analysis process.

For example, chart records are routinely scanned to identify erroneous data. While it is possible to develop computer programs to find the more blatant errors, chart records give a detailed view of the data and can be used with considerable ease in spotting a wide variety of errors. Typically it takes less than half an hour to organize and visually scan both the global and direct beam charts for one month. Keeping accurate maintenance records at the site enhances the usefulness of this scanning procedure.

The chart records are put to numerous uses. Clear days can be systematically identified from a visual inspection of the chart records. The data from these days are then used to check on the calibration of the instruments.

Power outages can be spotted and the time when power resumed can be determined from the charts because our data loggers automatically put hour marks on the charts (see Fig. 18). With our original UO DL this information was used to correct the time in the digitized data. The UO DL restarted automatically if the power had been down long enough to drain the battery, but the startup time was most easily established from the chart records. Chart records also show problems such as:

- the anomaly with the Eppley PSP pyranometer that occasionally results in a large response when the sun is at a specific angle at certain times of the year;
- the presence of ice or snow on the pyranometer;
- the misalignment of the pyrheliometer;
- dirt on the window of the pyrheliometer;
- and condensation on the inside window of the pyrheliometer.

Specific examples will be given in this section that show how chart records are utilized to find these problems and that point out the advantages of using charts as compared to computer programs. Before starting with the examples, the process used to obtain solar radiation data is briefly reviewed.

Data Monitoring System

The main component of our data monitoring system is a microprocessor based data logger (UO DL in the original network and Campbell Scientific CR-10 data loggers in the current network). With the UO DL, the input voltage signal was split after the preamp and one part of the signal was sent directly to the chart recorder. With the CR-10, a digital signal from the data logger is sent to a digital to analogue device that is connected to the chart recorders. If the data logger fails, the solar instruments are connected directly to the chart recorders.

MAY 13, 1984											SITE: HERMISTON		
DATE	YEAR DAY	HR	MIN	date logger, none ok	check tracker, target	adjust tracker (fine)	clean window	clean bulb	unwind cord	change cassette	change printer paper	change chart paper	COMMENTS:
SUN 13	134	7	09										(examples: power off, pyrheliometer off target, reset date logger, etc.)
MON 14	135	6	45	✓ 		✓	✓	✓					
TUES 15	136	6	44	✓ 		✓	✓						
WED 16	137	6	45	✓ 	6:45	✓	✓		✓	✓	✓		
THURS 17	138	6	45	✓ 		✓	✓						
FRI 18	139	6	45	✓ 	6:45	✓	✓						
SAT 19	140	6	53	✓ 		✓	✓						

Fig. 16: Typical log sheet used by site personnel to record the maintenance at the site.

A person working at the site maintains the solar monitoring equipment. Several times a week the instruments are cleaned, the alignment of the pyrheliometer is adjusted, and maintenance information is recorded on a log sheet such as shown in Fig. 16. Twice a month the chart records and the log sheets are sent to the UO Solar Monitoring Laboratory for data analysis.

Clear Day Analysis

One way to check for instrument deterioration is to monitor over time the transmission value of solar radiation at solar noon on clear days. Chart records are used to determine if the period around solar noon is clear. The criterion used to select clear periods is that both the global and direct beam charts have to be relatively smooth over the noon time hours. Some ambiguity exists over what is smooth enough to be considered a clear period, but by

being fairly selective all cloudy periods can be eliminated. This criterion is more restrictive than the use of cloud cover information from the weather service. By using charts to be more selective of the clear days the variance of the transmission values is reduced and a closer check on instrument deterioration can be maintained.

Misalignment of the Pyrheliometer

The pyrheliometer has an aperture opening angle of 5.7° . This aperture angle is large enough to allow for some of the inevitable tracking errors. The Eppley Normal Incidence Pyrheliometer (NIP) accepts about a 1.5° tracking error without appreciably affecting the data. Misalignments of the NIP by more than about 1.5° causes a significant reduction in the solar energy measured. To align the NIP there is a target on the back flange and a small hole in the front flange. When the pyr-

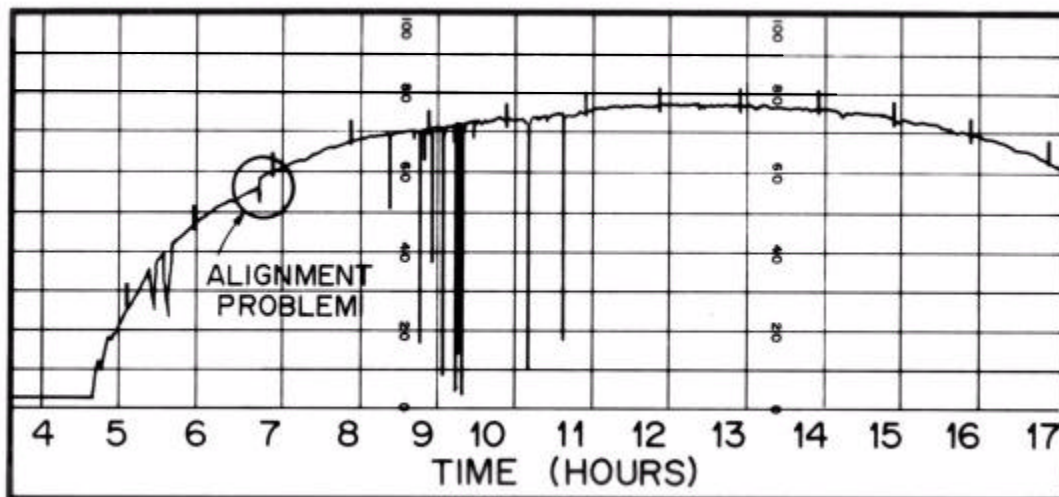

Fig. 17: Chart record for beam radiation. The pyrheliometer was out of alignment by more than 1.5° . The misalignment is also indicated on May 16 on the log sheet in Fig. 16.

heliometer is aligned with the sun, sunlight passes through the front hole and strikes the center of the target. As the alignment worsens, the sun spot moves towards the edge of the target. There is little measurable change until the sun spot starts to move off the target. Once off the target, the response drops rapidly.

The misalignment of the NIP can most easily be identified when the NIP is realigned. The magnitude of the tracking error can be determined from the relative change on the chart before and after realignment. Alternately the precision of the alignment can be estimated by noting where the sun spot is relative to the target. On our log sheets (see Fig. 16) we reproduce the target on the NIP and the site personnel mark the approximate location of the sun spot and note the time of the realignment.

The information on the log sheet aids us when we scan the chart records for potential inaccurate data. However, it is the chart record itself that we use to determine if the NIP is out of alignment. An error of 1%-2% (this is about 1 mm on the chart) can be seen on the charts whereas the log sheets only indicate that the NIP may be out of alignment. (It is rare to see the NIP out of alignment by only a few per

cent due to the rapid fall off once the pyrheliometer moves out of alignment.)

If the NIP has to be realigned on a sunny day, the alignment problem is fairly easy to spot as shown in Fig. 17. Subsequent to being aligned, these data were low by about 5%. Computer programs using 1 or 5 minute data might detect the change in performance. However, visual inspection is necessary to distinguish between the disappearance of a thin cloud or haze and the realignment of the NIP. When the NIP is out of alignment, chart records show an abrupt jump when the NIP is aligned. Often, plots of 5 minute data can be used to identify the alignment of the NIP, but there is always some concern when the change is small.

Charts and log sheets are also useful in determining how long the NIP has been out of alignment. An estimate can be made with knowledge of when the pyrheliometer was last aligned, the daily change in declination, and the magnitude of the alignment problem as determined from the charts.

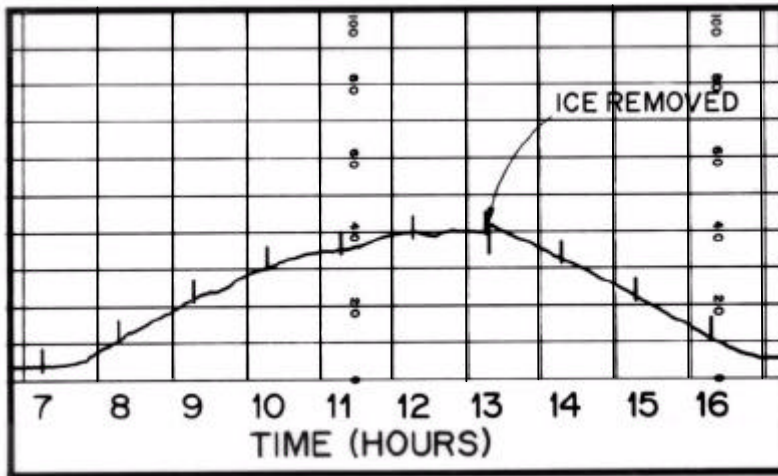

Fig. 18: Plot of global radiation. Bulb of pyranometer was covered with ice during most of the day.

Misalignment of Tracker

In order for the NIP to stay aligned for the longest possible time, the tracker on which the NIP is mounted must be aligned due south. If the tracker is not aligned due south, the pyrheliometer will at first be out of alignment in the morning or evening while being aligned for the rest of the day. If this problem occurs, the curve on the direct beam chart will start to flatten out in the morning or evening hours as the NIP moves out of alignment. This is one case where the chart record can be used to spot a serious problem.

Ice on Pyranometer

Ice or snow on the pyranometer bulb can seriously affect the measurement and is often difficult to detect. Sometimes only the ice on the front of the bulb melts and additional light is reflected from the back of the bulb leading to extremely high readings. It should be possible to design computer programs to spot these problems especially when beam data are available to indicate whether it is a clear period. At other times the ice only marginally affects the results as shown in Fig. 18. On clear days it is fairly easy to spot periods during which ice affects the measurements, because the data do not match the correct shape and smoothness of the clear day curve.

An Anomalous Problem with the Eppley PSP

There is an anomalous problem with the Eppley PSP. For example, in Eugene on clear days during October and March around 9-10 o'clock the data occasionally starts to dip slightly and then rises considerably above the normal value. The data values then drop back slightly below normal and eventually return to normal. This all occurs over an hour or two. This anomaly always occurs when the sun is at a specific angle with respect to the pyranometer. It does not occur with all pyranometers and the characteristics are peculiar to each pyranometer.

The sensor on the Eppley PSP is a black disk surrounded by a metal ring (see Fig. 19). At the proper angles, internal reflects from the bulb of the pyranometer causes a bright spot to form near the sensor. When conditions are just right, the spot moves across the ring and onto the black disk. As the sun's position changes, the spot moves off the disk and the data return to normal. This unusual condition can happen twice a year when it is clear and the sun is at the right position in the sky.



Fig. 19: Spot of light moves across PSP sensor.

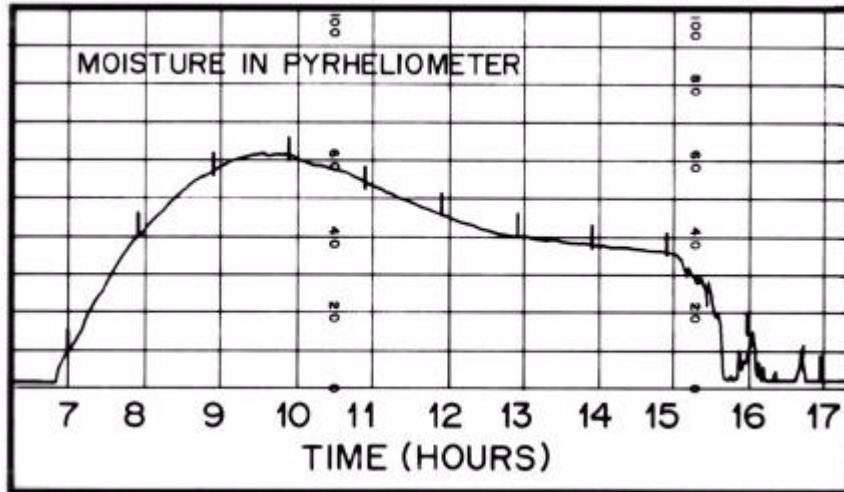

Fig. 20: Plot of beam radiation. Moisture entered the pyrhelimeter through a broken seal and condensed on the window, reflecting some of the incoming radiation.

Moisture in the Pyrhelimeter

If the window seal of the pyrhelimeter breaks, moisture can get inside. The moisture will condense on the inside of the window and reduce the direct signal. Sometimes the site person can spot condensation inside the window, but this is a difficult problem for the site person to see. Occasionally the moisture will

evaporate and readings will return to normal. Other times the problem becomes worse over the day. A typical example is shown in Fig. 20. This problem can be distinguished from a misalignment of the pyrhelimeter by the way the effect varies over the day. It does not disappear when the pyrhelimeter is realigned.

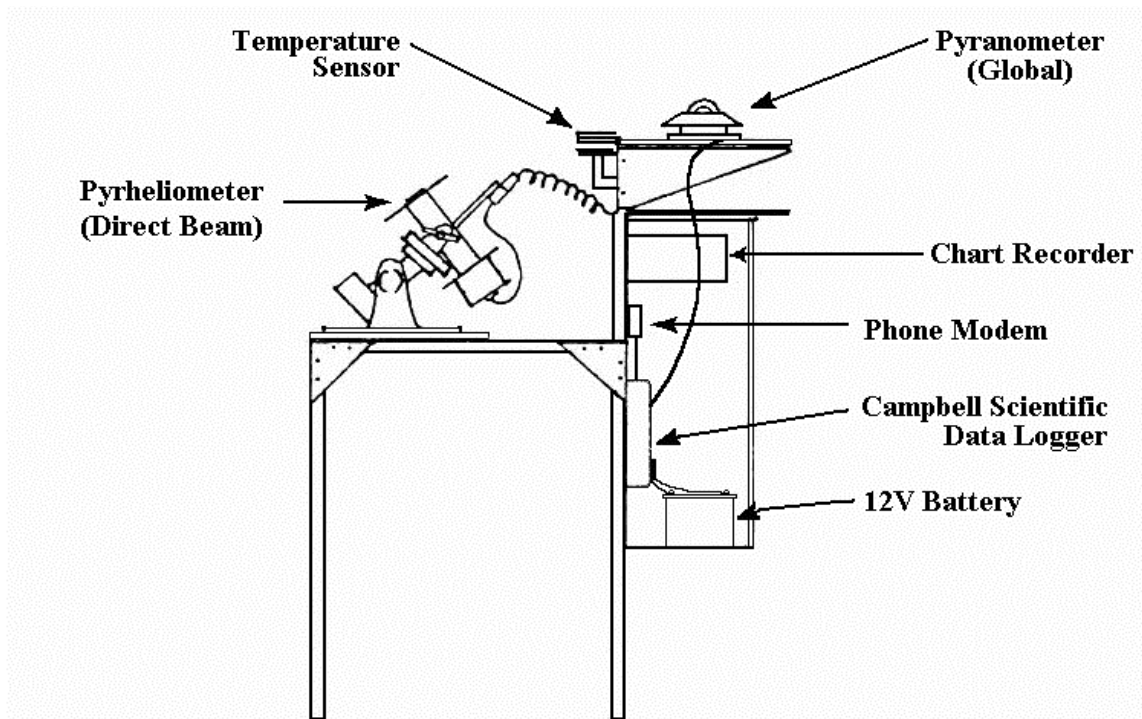

Diagram of Solar Monitoring Installation